

ULTRA CLEAN POLYPROPYLENE STORAGE PLATES CATALOGUE



Are your plates whiter than white? Or do they harbour a dirty secret?

Deep well polypropylene microplates are commonly used for sample storage in life science laboratories. An essential aspect of the manufacture of these plates is the selection of clean raw materials for injection moulding. Polypropylene is an inert and heat resistant material, ideal for sample storage. However, all grades of polypropylene are not the same, for example, Injection moulding grades of polypropylene often have high concentrations of chemicals to aid the moulding process.

This allows rapid production of plates and lower costs, but may compromise the integrity of samples or compounds which are stored in such plates for extended periods. The problem is particularly acute where compounds are stored as solutions in solvents such as methanol or DMSO, as these excellent solvents have a tendency to extract from the polypropylene base material any added extractable compounds such as mould release agents or polymer flow improvers.

Porvair Sciences has carried out tests on many manufacturers' deep well plates to establish levels of extractables in each. A typical example is illustrated. Samples of deep well microplate for testing were obtained from all the major manufacturers. A new unused plate was selected from each batch and subjected to a stream of clean, dry compressed air to remove any particulates that may have accumulated. Testing for polymer leachate and extractable contamination was performed by incubating overnight an appropriate volume of HPLC grade methanol in three wells in each sample plate. The methanol was spiked with 10ug/ml of Caffeine as an internal standard. The plates were sealed with a friction seal and left to stand overnight.

After overnight incubation, 1µl aliquots of each well sample were subjected to analysis on a GC-MS system using splitless injection at 250°C.

Separation was performed on a capillary column using the appropriate temperature gradient. Detection was by positive ion EI-MS.

In order to simplify the full data set here, results from each of the three wells per plate tested have been combined and averaged.

Results from the GC-MS showed good performance from the Porvair microplate, with a clean caffeine peak and no significant levels of leachable or extractable compounds. Plate B shown here, is a

typical example of the other commercial microplates tested, which included two major German manufacturers and several other well-known suppliers. These variously displayed extra peaks with a variety of retention times across the run, indicating several different contaminants. Further analysis of these extra peaks revealed that they were, indeed, mostly recognized chemicals used as additives in the polypropylene to assist the injection moulding process.

From this it can be seen that it is essential to select the correct grade of polypropylene material for storage plate manufacture. The full report can be downloaded from our website.

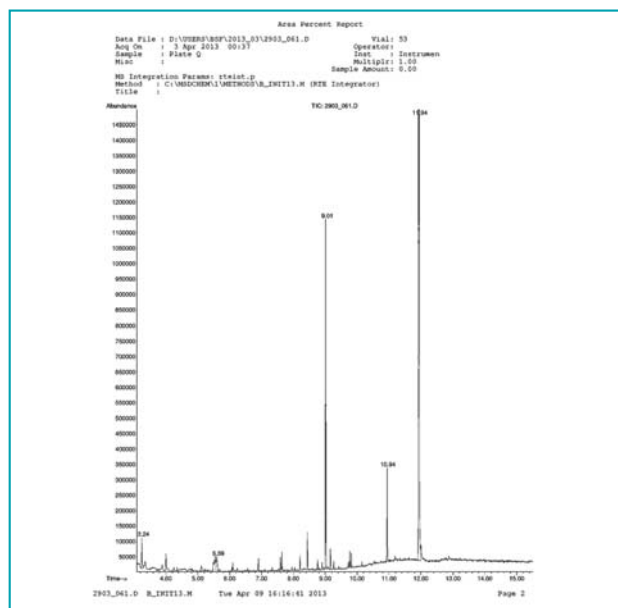
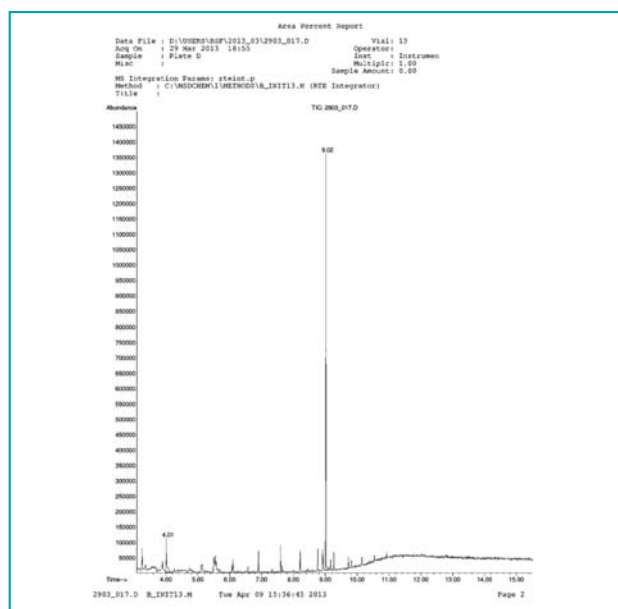

96-well shallow round 14.7mm height

Porvair Sciences has developed a number of storage/collection plates to help in the fields of cell biology, molecular biology, drug discovery, combinatorial chemistry, screening and genomics. The plates are manufactured under clean room conditions and a significant number are DNase/RNase free. They are mainly made from polypropylene, an inert material giving heat and solvent resistant qualities. Porvair Sciences offers the largest combination of well shape, number of wells and well volume on the market. Each is made to the ANSI/SLAS format for compatibility with most readers/washers and automated equipment.

Porvair Sciences offers three plates with well capacities of 350µl, 270µl and 220µl. They have flat-, round- or V-bottoms and can be used for compound storage and culturing.

- *Manufactured in polypropylene*
- *Alphanumeric grid reference*
- *Round and V-bottom allow greater liquid removal and particulate collection*
- *Raised rims improve sealing and stop cross contamination*

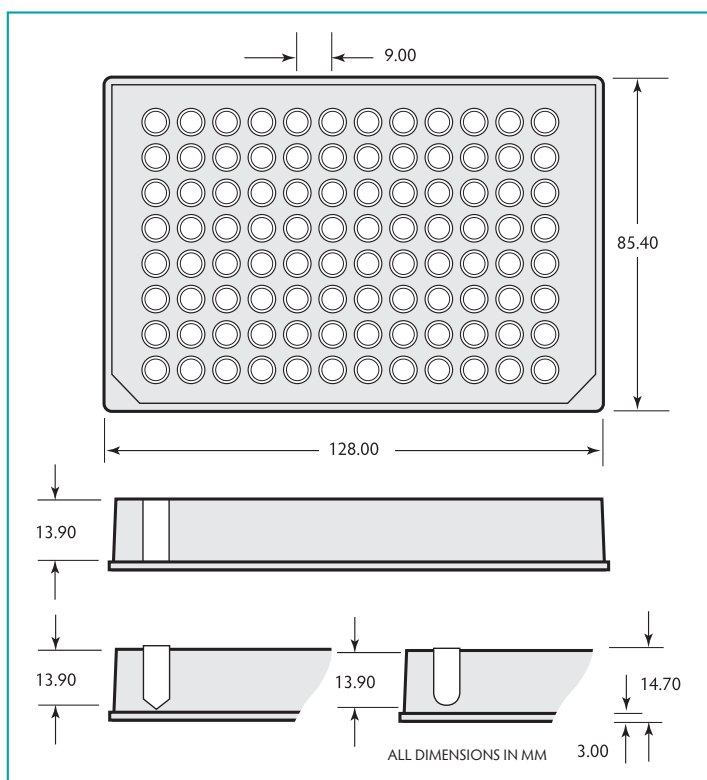
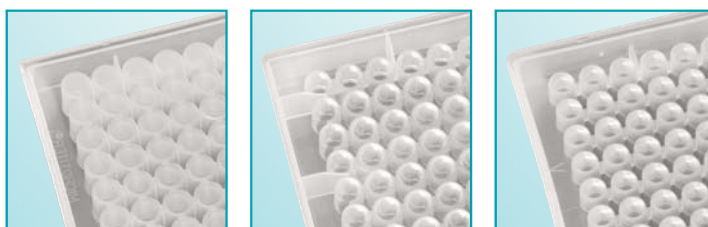
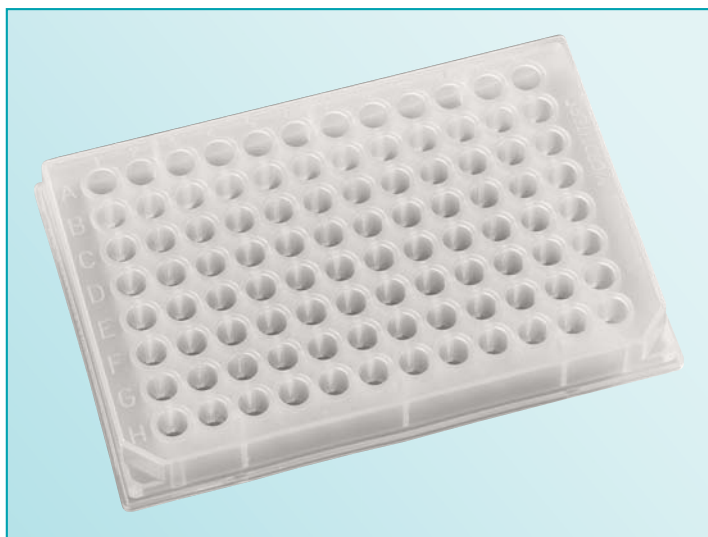

Storage plates round

Rim and bottom well shape	Material	Well volume	Sterile	Quantity/case	Cat. no.
No rim, flat	Polypropylene	350µl	–	100	208003
Raised-round	Polypropylene	270µl	–	100	209003
Raised-V	Polypropylene	220µl	–	100	210003

96-well deep square

44mm height

The family of 96 square well plates was designed so that it would make the interchange of plates simpler in automated systems. All three plates have the same geometry and the only variable is the well depth.

- Made from virgin polypropylene
- Tested for low extractables
- V bottom to allow total liquid removal, partial collection and to aid re-suspension
- No inner edges to allow better collection of magnetic beads
- DNase/ RNase free
- Working volumes of 350µl, 1ml, and 2ml
- Raised well rims to improve heat sealing
- Conical base which aids sample concentration, reconstitution and centrifugation
- Sterile and non-sterile versions available
- Toughened genomics version for seed and leaf grinding

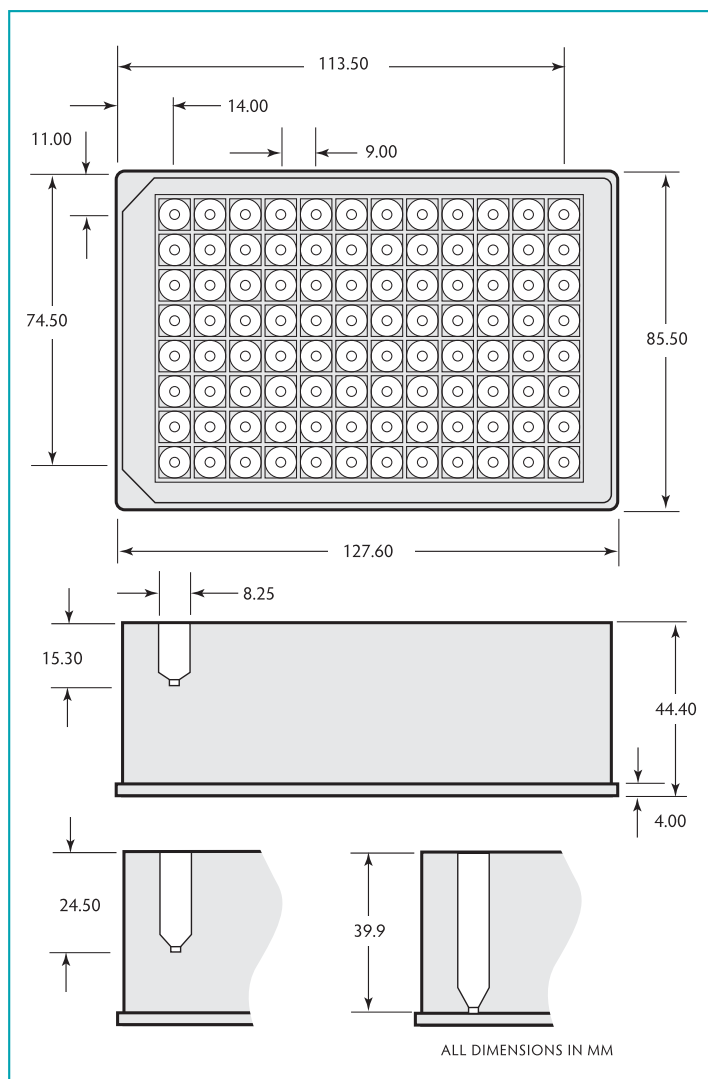

Drawing of 500066 available on request.

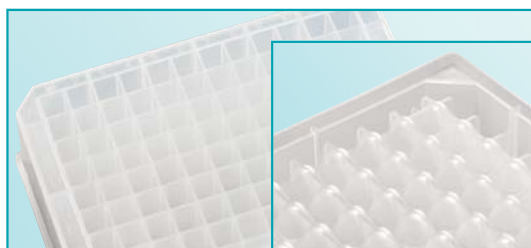

Storage plates 96 square well

Description	Well volume	Sterile	Use cap mat	Quantity/case	Cat. no.
Polypropylene, pyramid bottom	2.0ml	–	219004	50	219009
Polypropylene, pyramid bottom, sterile, inner bag of 5	2.0ml	✓	219019	50	219027
Polypropylene, pyramid bottom, toughened for genomics	2.2ml	–	219004	50	219030
Polypropylene, pyramid bottom, toughened for genomics	2.2ml	✓	219004	50	219031
Polypropylene, pyramid bottom	1.0ml	–	219004	50	219008
Polypropylene, pyramid bottom, sterile, inner bag of 5	1.0ml	✓	219019	50	219026
Polypropylene, pyramid bottom	350µl	–	219004	50	219006
Polypropylene, pyramid bottom, sterile, inner bag of 5	350µl	✓	219019	50	219025

Deep well round 1ml 42mm height

The plates are made in virgin polypropylene to minimise extractables. Working volume is 1ml per well and total volume is 1.1ml. Coloured plates aid identification when retrieving from storage. Black plates are suitable for storing light sensitive compounds.

- Manufactured from pre-tested polypropylene for low extractables
- Alphanumeric grid-referencing
- DNase/ RNase free
- Packed in sealed sleeves of 5 plates
- Rimmed version to stop cross contamination and enable a better seal
- Non rimmed version to allow insertion of vials, or where the seal is not crucial
- Cylindrical well with round bottom for optimal mixing and recovery
- Very easy to use with automated sample handling systems
- Can be stored at -80°C

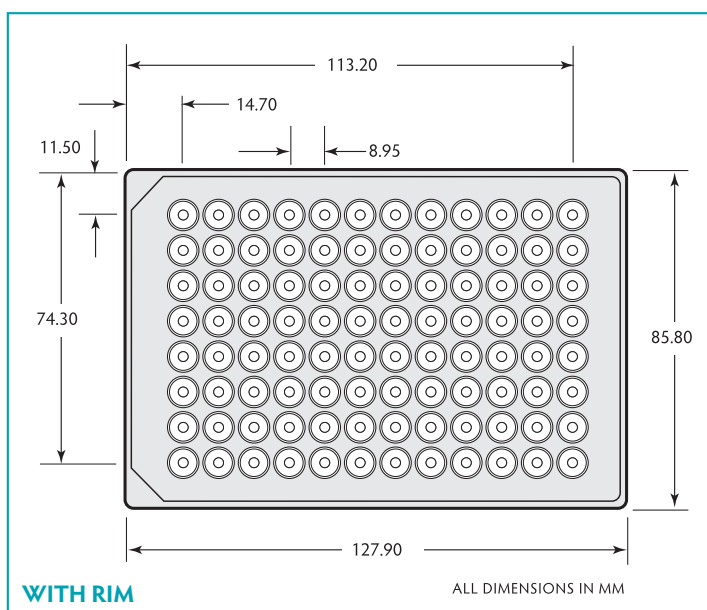
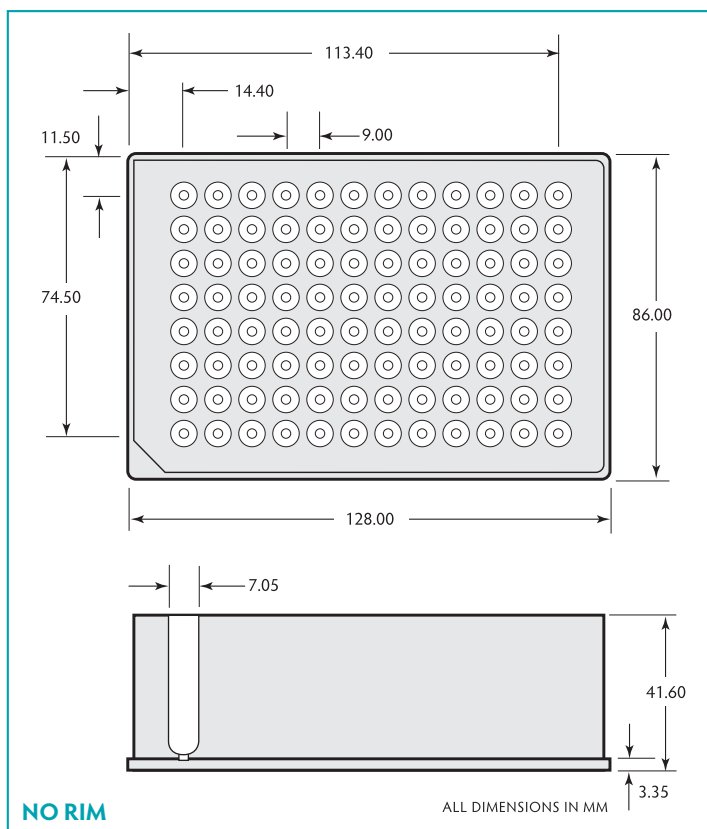
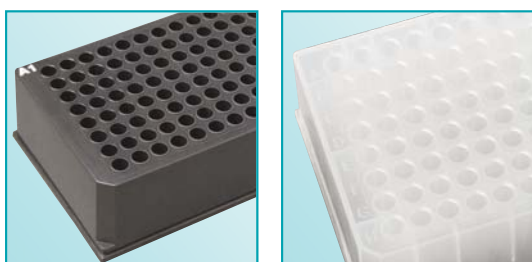

Polypropylene storage plates round

Rim and bottom well shape	Colour	Well volume	Sterile	Use cap mat	Quantity/case	Cat. no.
Raised- round	Natural	1ml	–	219036	50	219002
Raised- round	Natural	1ml	✓	219042	50	219012
No rim- round	Natural	1ml	–	219036	50	219037
Raised- round	Black	1ml	–	219036	50	219412

96-well deep round 'common wall' 45mm height

These revolutionary plates are made in virgin polypropylene to minimise extractables. Maximum volume is 2.075ml per well and working volume is a useful 1.85ml, more than any other comparable '2ml Round Well' plate in this class. The 'common wall' design allows the highest possible volume to be used whilst maintaining an overall height of just 45mm, complete with ANSI/SLAS standard base and footprint. Extra working volume is thus assured in a convenient round bottom, round well format.



- Manufactured from pre-tested polypropylene for low extractables
- Alphanumeric grid-referencing
- DNase/ RNase free
- Packed in sealed sleeves of 5 plates
- Cylindrical well with round bottom for optimal mixing and recovery
- Very easy to use with automated sample handling systems
- Can be stored at -80°C
- Easily sealed with matching Cap Mat or heat seal
- Fits Waters AcQuity™ autosamplers

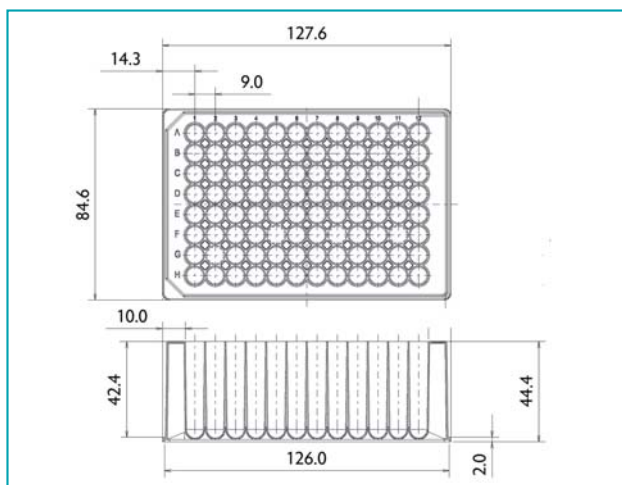

96-well round low profile

A new introduction to the Porvair range is a low profile 1.2ml 96-well round plate with a height of just 27mm. This allows more plates to be stored or stacked in a given space. The plates are made with extractable-free polypropylene for excellent results. A specific anti-evaporation cap mat is also available for this plate manufactured from thermoplastic elastomer.

- Allows stacking in higher densities
- Minimises space needed for compound storage
- Pure virgin polypropylene
- Matching snug-fitting cap mat

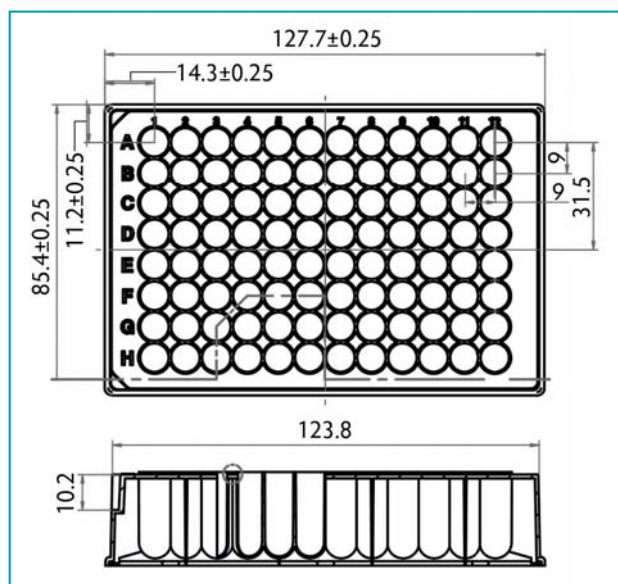

96-well round low profile

Description	Working well vol	Sterile	Qty/case	Cat. no.
96-well round low profile plate	1.1ml	–	50	219250

96-well deep round 'common wall'

Description	Pk/Qty	Part No.
96 deep well, 2ml/well Polypropylene round well rimless DNA/RNAase free, inner bag of 5	50	219020
96 deep well, 2ml/well Sterile Polypropylene round well rimless DNA/RNAase free, inner bag of 5	50	219021

1.1ml round well, round bottom, magnetic separation plate

Porvair Sciences new style 1ml microplate is designed to optimize performance on all popular liquid handling automated platforms and manual workstations with locators for incubation functionality and/or magnetic separations. The bottom geometry of these plate easily fits over heating and cooling post arrays designed to fit between the well walls. The design also accommodates a variety of magnet arrays to support bead-based separation assays. This microplate is molded with high purity, medical grade, polypropylene homopolymer in a DNase/RNase free ISO9001 certified environment and is available irradiated or with laser etch barcode ready white pigment. The plate can be sealed with clear and aluminum heat seals or with a variety of adhesive seals from the Porvair Sciences range.



1.1ml round well, round bottom, magnetic separation plate

Description	Quantity/pack size	Cat. no.
1ml round well magnetic plate 96-well	25	360121
1ml round well magnetic plate 96-well	25	360122
1ml round well magnetic plate 96-well white	25	360123

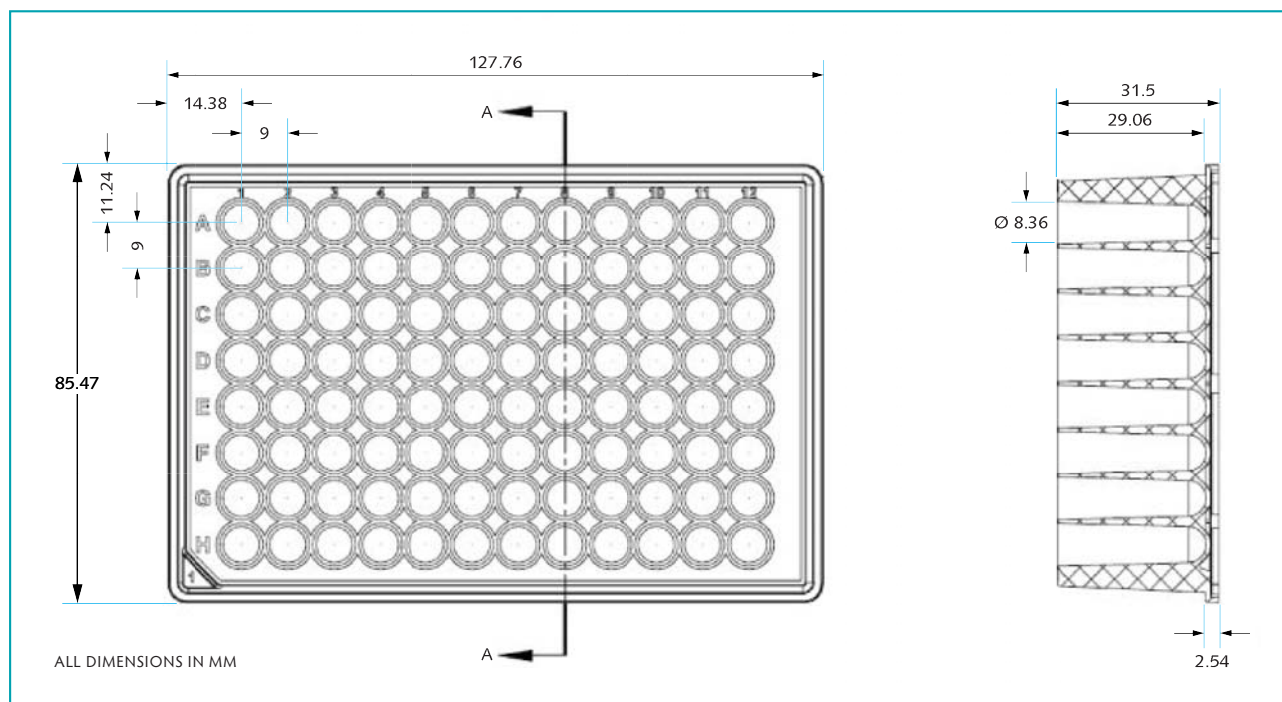

384-well square

Porvair Sciences has a selection of 384-well polypropylene plates to suit most applications. All of them are made from pre-tested polypropylene in Class 100000 clean rooms.

- Manufactured for high density sample collection / storage
- Two sizes: 58µl and 300µl per well working volume
- Each are designed to allow almost total removal of liquid sample
- Extra flat – allows plate sealing
- Storage temperature down to –80°C
- Available sterile and non sterile
- All manufactured to ANSI/SLAS specifications

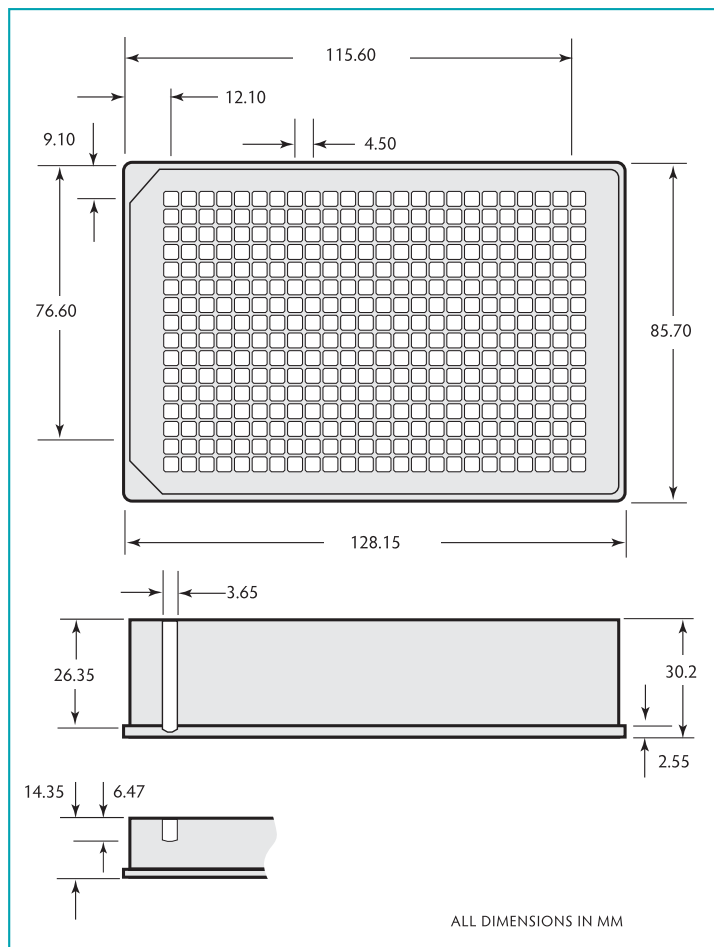

Storage plates 384-well

Well shape, top & bottom	Working well vol	Sterile	Qty/case	Cat. no.
Square-round	58µl	–	60	224001
Square-V	300µl	–	48	219040
Square-V	300µl	✓	48	219041

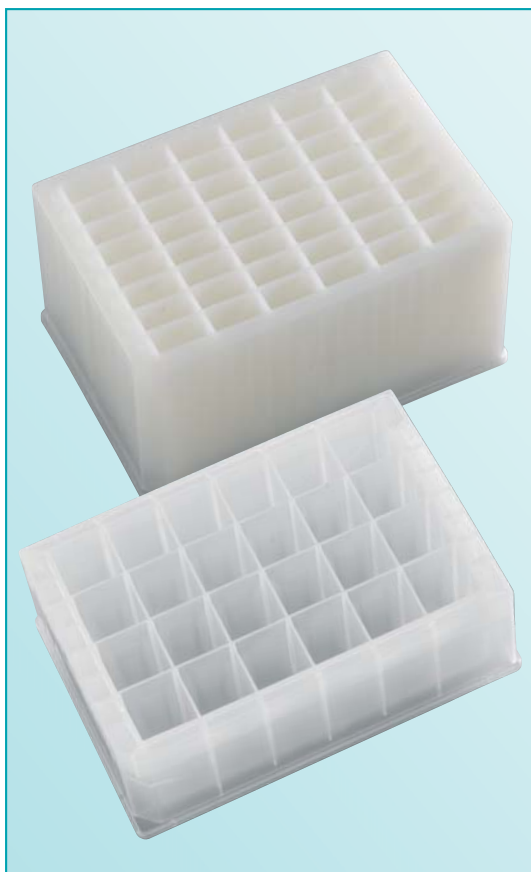

Large volume deep well plates

The range of large volume plates is designed to meet special requirements. Focused on the combinatorial, environmental and food technology markets, it allows large volumes of samples to be transported in recognised ANSI/SLAS format microplates, to allow greater automation. Plates will accept the Porvair universal lid (see page 55). All plates are manufactured from virgin polypropylene, can be heat sealed and stored for prolonged periods at -80°C.

24-well features:

- 24 wells with a working capacity of 10ml/well
- Standard height (44mm) of a deep well plate
- Sterile or non sterile versions
- Lidded version available

48-well features:

- Two versions:
- 5ml/well, 44mm high
- 7ml/well, 68mm high

High volume deep well microplates

Well shape, bottom shape	No of wells	Working well vol	Sterile	Lid	Qty/ case	Cat. no.
Rectangle, V-bottom	24	10ml	–	–	25	360013
Rectangle, V-bottom (bulk pack)	24	10ml	✓	–	25	360115
Rectangle, V-bottom	24	10ml	–	✓	25	360077
Rectangle, V-bottom (single pack)	24	10ml	✓	✓	25	360079
Rectangle, V-bottom (with bar code)	24	10ml	✓	✓	25	360080
Rectangle, round-bottom	24	10ml	–	–	25	360117
Rectangle, V-bottom	48	5ml	–	–	25	360002
Rectangle, V-bottom	48	7ml	–	–	30	360004

- Available for the 2ml and 1ml square and 2mm round deep well plates
- Easily fitted below plates
- Made from impact resistant silicone

Centrifuge support plate

The support plate is designed to fit into the skirt of the deep well plates. This then allows the plate to be used in a centrifuge at 3,500G or GenoGrinder® without the risk of the plate distorting and causing the well to leak.

Deep well microplate accessories

Description	Quantity/pack size	Cat. no.
Centrifuge support plates for 219008 & 219026	2	500150
Centrifuge support plates for 219009 & 219027	2	500114
Centrifuge support plates for 219020 & 219021	2	500180
Centrifuge support plates for 360004	2	500212

Bacti-growth plates

Bacti-growth plates are specially packaged plates to allow the growth of bacteria, yeast, mammalian or insect cell lines.

Using only the highest-grade raw materials, our plates are tested to ensure no moulding or polymer contaminants leach out into the samples. This guarantees reproducibility and maintains customer confidence. Each Bacti-growth plate consists of a deep well plate and a tight fitting lid, packed sterile in bags.

- Plate well configuration available from 24- through to 384-well
- Well volumes from 300µl through to 10ml per well
- Round and square well available
- Sealed in sterile bags of 5 plates
- Robot friendly
- Manufactured to the highest specifications
- Conform to the ANSI/SLAS format



Bacti-growth plates

Description	Sterile	Lid	Qty/Pack	Cat. no.
24 x 10ml square wells, polypropylene with lid	✓	✓	25	360080
96 x 1ml round wells, polypropylene with lid	✓	✓	25	219101
96 x 2ml square wells, polypropylene with lid	✓	✓	25	219102
96 x 2ml round wells, polypropylene with lid	✓	✓	25	219022

Plate lids

Polystyrene and polypropylene lids are available for all 96-well SBS standard plates. See 229125 and 229128 in the table opposite.



Friction seals

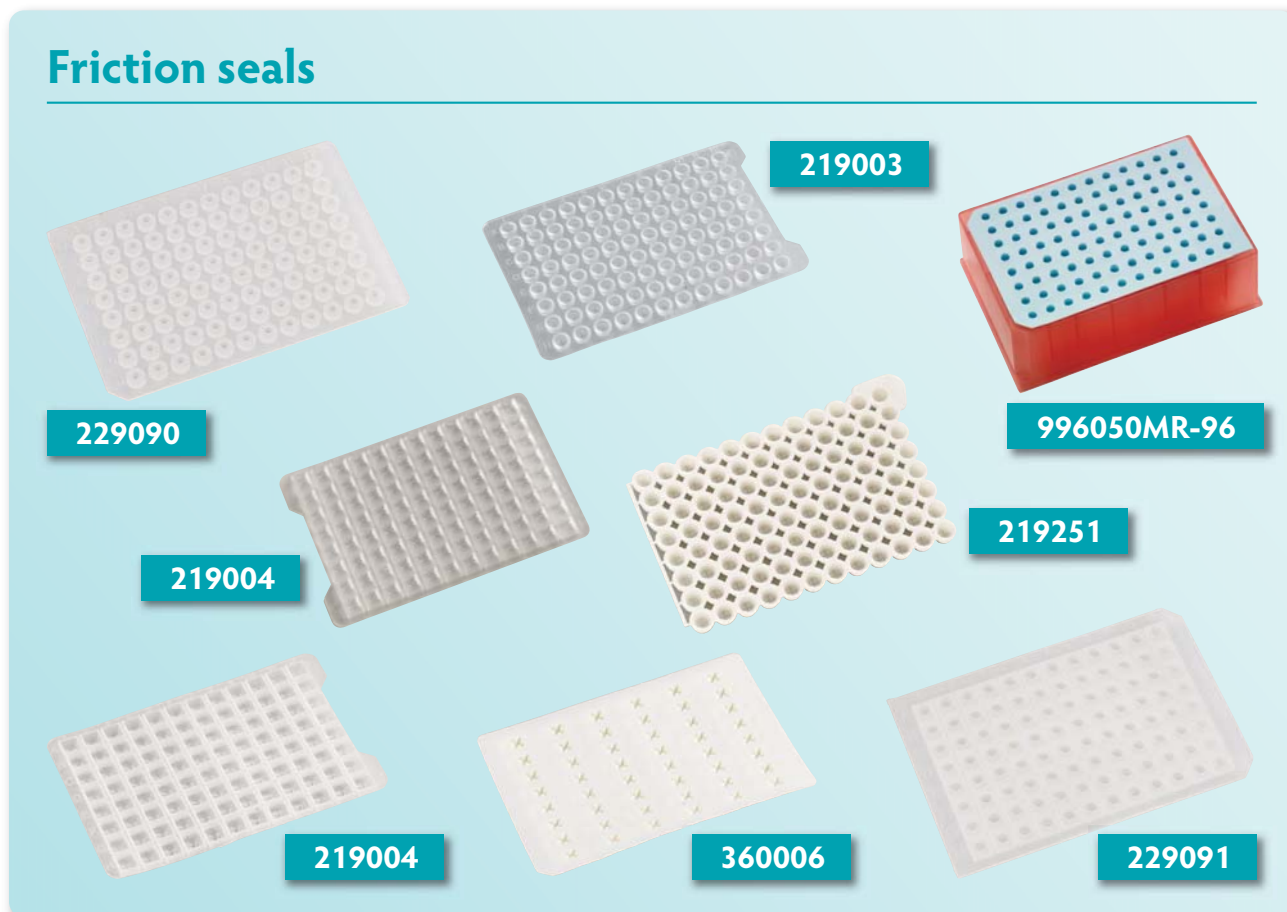

Friction seals (cap mats)

Description	Cross reference to Porvair Sciences plates	Qty/pack	Cat. no.
Silicone sealing mat to fit 384-well plates	219040, 219041	50	380001
EVA sealing mat to fit 96-square well plates	219006, 219008, 219009	50	219004
EVA sealing mat to fit 96-square well plates, sterile	219025, 219026, 219027	50	219019
Pierceable Santoprene mat for 96-square well plates	219006, 219008, 219009	100	360010
EVA sealing mat for 96-round well plates	219002, 219032	50	219036
EVA sealing mat for 96-round well plates, black	219002, 219032	50	219038
EVA sealing mat for 96-round well plates, sterile	219012	50	219042
Pierceable Santoprene seal strip to fit 24-well plates	360013	100	360014
Pierceable Santoprene seal mat to fit 48-well plates	360002, 360004	100	360006
Pierceable Santoprene seal strip to fit 96-well plates	360001	400	360007
Pierceable sealing cap, round 96-well	219002	50	219044
Mat for round 96-well plates (standard silicone)	219002 and round well plates	5	229090
Mat for square 96-well plates (standard silicone)	229230 and square well plates	5	229091
Mat for round 96-well plate (PTFE coated silicone)	219002 and round well plates	5	229092
Mat for square 96-well plate (PTFE coated silicone)	229230 and square well plates	5	229093
Polystyrene clear lid for all 96-well SBS standard plates	Fits all plates	100	229125
Polypropylene lid for all 96-well SBS standard plates	Fits all plates	100	229128
Cap mat for 1.1ml low profile storage plate	219250	5	219251
96-well PCR sealing mat, natural	For rimless PCR plates	50	286113
96-well PCR sealing mat, rubber, natural	For rimless PCR plates	50	286114
8-well PCR sealing strip, 125 strips per pack, 10 packs per case	–	1250	286116

Deep-well plates selection guide

Porvair Sciences is a leading manufacturer of high quality polypropylene deep-well microplates for applications including compound storage, fraction collection, sample mixing and preparation. Using only virgin extractable-free grades of polymer in the production process ensures that you get reliable reproducible results free from contamination each time. This guide will suggest the best deep-well plate options for your particular area of research.

Polypropylene is a naturally-opaque white polymer which in its raw untreated state is intrinsically hydrophobic and offers a medium-low bind surface for proteins and peptides. In addition, it also acts as a low-attachment surface for adherent cells. These properties can be modified, or enhanced, by further treatment, for example, coating with very low binding compounds.

Polypropylene can be sterilised using gamma radiation, by treatment with ethylene oxide or by autoclaving at 121°C. However, as the melting point of pure homopolymer is 171°C, and the commercially available grades 160 – 166°C, autoclaving of polypropylene deep-well plates is not recommended. This is because some softening of the polymer will be observed and this can lead to distortion of the plate structure and consequent deviation from the strict ANSI/SLAS microplate dimensions. Ethylene oxide sterilisation can also be problematic due to the oxidative nature of the process which can transform the natural hydrophobic surface into a strongly hydrophilic surface.

Deep-well plates can have various geometries depending on the shape of the well and also the profile of the well bottom. The most common geometries are square-well plate with pyramid, or V-shape, bottoms and round-well plates with round bottoms. The advantage of the square V-well is very high recovery of compounds from these low-dead volume plates. Whilst round-well plates exhibit higher dead volumes, they do allow for excellent mixing and are useful in bead-beating applications where beads might otherwise get stuck in the tight bottom of a V-well.

The height of a deep-well plate will normally determine the maximum volume, but in recent years space has been saved through the use of 'common wall' designs in round-well format that use larger diameter wells to reduce height and maximise volume. These designs can also allow more plates to be fitted into equipment such as HPLC autosamplers, incubators and the like.

When selecting round-well plates, it is important to consider whether sealing will be accomplished by an adhesive seal, a friction seal (or cap mat) or through thermal sealing with a welded foil. In the case of adhesive seals, rimless plates with a completely smooth top surface are preferable. For friction seals, either rimmed or rimless work best, whereas for heat weld sealing, a raised rim is essential. This does not really apply to square-well plates as the divisions between wells act like rims anyway.

The flow chart on the following pages is designed to help you select the correct plate for your application.



96-well deep square

Description	Well volume	Sterile	Use cap mat	Qty/case	Cat. no.
Polypropylene, pyramid bottom	2.0 ml	×	219004	50	219009
Polypropylene, pyramid bottom, sterile, inner bag of 5	2.0 ml	✓	219019	50	219027
Polypropylene, round bottom	1.6 ml	×	219004	50	500066
Polypropylene, pyramid bottom	1.0 ml	×	219004	50	219008
Polypropylene, pyramid bottom, sterile, inner bag of 5	1.0 ml	✓	219019	50	219026
Polypropylene, pyramid bottom	350 µl	×	219004	50	219006
Polypropylene, pyramid bottom, sterile, inner bag of 5	350 µl	✓	219019	50	219025
Polypropylene, pyramid bottom, seed genomics	2.0 ml	×	219033	50	219030
Polypropylene, pyramid bottom, seed genomics, sterile, inner bag of 5	2.0 ml	✓	219019	50	219031

96-well deep round

Rim and bottom well shape	Colour	Well volume	Sterile	Use cap mat	Qty/case	Cat. no.
Polypropylene, raised-round DNA/RNAase free, inner bag of 5	Natural	1 ml	×	219036	50	219002
Polypropylene, raised-round DNA/RNAase free, inner bag of 5	Natural	1 ml	✓	219042	50	219012
Polypropylene, rimless-round DNA/RNAase free, inner bag of 5	Natural	1 ml	×	219036	50	219037
Polypropylene, raised-round DNA/RNAase free, inner bag of 5	Blue	1 ml	×	219036	50	219432
Polypropylene, raised-round DNA/RNAase free, inner bag of 5	Red	1 ml	×	219036	50	219422
Polypropylene, raised-round DNA/RNAase free, inner bag of 5	Black	1 ml	×	219036	50	219412
Polypropylene, rimless-round DNA/RNAase free, inner bag of 5	Natural	2 ml	×	500179	50	219020
Polypropylene, rimless-round DNA/RNAase free, inner bag of 5	Natural	2 ml	✓	500179	50	219021

96-well deep round 'common wall'

Description	Qty/pack	Part No.
96 Deep well, 2 ml/well, Polypropylene round well rimless, DNA/RNAase free, inner bag of 5	50	219020
96 Deep well, 2 ml/well, Sterile, Polypropylene round well rimless, DNA/RNAase free, inner bag of 5	50	219021

96-well shallow round

Rim and bottom well shape	Material	Well volume	Sterile	Qty/case	Cat. no.
No rim, flat	Polypropylene	350 µl	×	100	208003
Raised-round	Polypropylene	270 µl	×	100	209003
Raised-V	Polypropylene	220 µl	×	100	210003

Large volume microplates

Well shape, bottom shape	No of wells	Working well volume	Sterile	Lid	Qty/case	Cat. no.
Rectangle, V-bottom	24	10 ml	×	×	25	360013
Rectangle, V-bottom (bulk pack)	24	10 ml	✓	×	25	360115
Rectangle, V-bottom	24	10 ml	×	✓	25	360077
Rectangle, V-bottom (single pack)	24	10 ml	✓	✓	25	360079
Rectangle, V-bottom (with bar code)	24	10 ml	✓	✓	25	360080
Rectangle, round-bottom	24	10 ml	×	×	25	360117
Rectangle, V-bottom	48	5 ml	×		25	360002
Rectangle, V-bottom	48	7 ml	×		30	360004
Polystyrene Universal SLAS Lid	24/48/96	–	×	✓	100	229125

384-well

Well shape, top & bottom	Working well volume	Sterile	Qty/case	Cat. no.
Square-round	58 µl	×	60	224001
Square-V	300 µl	×	48	219040
Square-V	300 µl	✓	48	219041

CHOOSE THE NUMBER OF WELLS, OR PLATE FORMAT YOU NEED

<500 µl – use a 350 µl plate

CHOOSE THE WELL BOTTOM

Round bottom –
good mixing 14mm high **209003**

Flat-well bottom –
highest volume 14mm high **208003**

270 µl V-well –
high recovery 14mm high **210003**

350 µl V-well –
high recovery 45mm

CHOOSE STERILITY

Sterilised by gamma radiation **219025**

Unsterilised **219006**

96-WELL
MICROPLATES

OR >500 µl <1 ml – use a 1.1 ml plate

CHOOSE WELL SHAPE

1.1 ml round-well, round bottom – good mixing

1 ml square-well, V-bottom – good recovery

CHOOSE HEIGHT

27mm high

44mm high

Common wall rimless,
natural PP **219250**

CHOOSE RIM

Rimless, natural PP
non-sterile **219037**

Rimmed

CHOOSE STERILITY

Sterilised by gamma
radiation, natural PP **219012**

Unsterilised

CHOOSE STERILITY

Sterilised by gamma radiation **219026**

Unsterilised **219008**

CHOOSE COLOUR & TYPE

Natural – **219002**

Red – for easy
identification **219422**

Black – for light sensitive
operations **219412**

Blue – for easy
identification **219432**

96-WELL
MICROPLATES

OR >1 ml <2 ml - use a 2.2 ml plate

96-Well MICROPLATES

CHOOSE WELL SHAPE

Round-well, round bottom – good mixing

CHOOSE STERILITY

Sterilised by gamma radiation **219021**

Unsterilised **219020**

Square-well, V-bottom – good recovery

CHOOSE STERILITY

Sterilised by gamma radiation

Unsterilised

CHOOSE TYPE

For everyday use **219027**

For bead-beating **219031**

For everyday use **219009**

For bead-beating **219030**

CHOOSE TYPE

OR >4.8 ml <10 ml

24/48-Well MICROPLATES

CHOOSE VOLUME OF RECTANGLE-WELL

48 x 4.8 ml square-well, non-sterile **360096**

48 x 5 ml rectangle-well non-sterile **360002**

24 x 10 ml square-well

CHOOSE STERILITY

Sterilised by gamma radiation **360115**

Unsterilised **360013**

384-Well MICROPLATES

CHOOSE VOLUME OF RECTANGLE-WELL

58 µl per well, not sterile **224001**

300 µl per well

CHOOSE STERILITY

Sterilised by gamma radiation **219041**

Unsterilised **219040**

Accounts

Porvair plc
7 Regis Place
Bergen Way Kings Lynn
Norfolk UK PE30 2JW
Tel: 44 (0)1553 765500
Fax: +44 (0)1553 765599

Customer Services and Sales Office

Porvair Sciences Ltd
Clywedog Road South
Wrexham Industrial Estate
Wrexham North Wales
UK LL13 9XS
Tel: +44 (0) 1978 666240/666239
Fax: +44 (0) 1978 660007
email: int.sales@porvair-sciences.com
www.microplates.com

Porvair Sciences offers a complete range of microplates for storage, collection, assays, ELISA and tissue culture. For detailed information on our other products, including tissue culture plastics and our revolutionary CAIP Chromatin preparation kits, please request our other brochures or visit our website www.microplates.com

Porvair Sciences catalogue of microplates
& microplate equipment (72 pages)



Porvair Sciences chromatography
supplies catalogue (28 pages)



Porvair Sciences assay plates
brochure (16 pages)

